

Closed Couple Electric Pumps

- High Efficiency motors standard
- Wide variety of applications and conditions

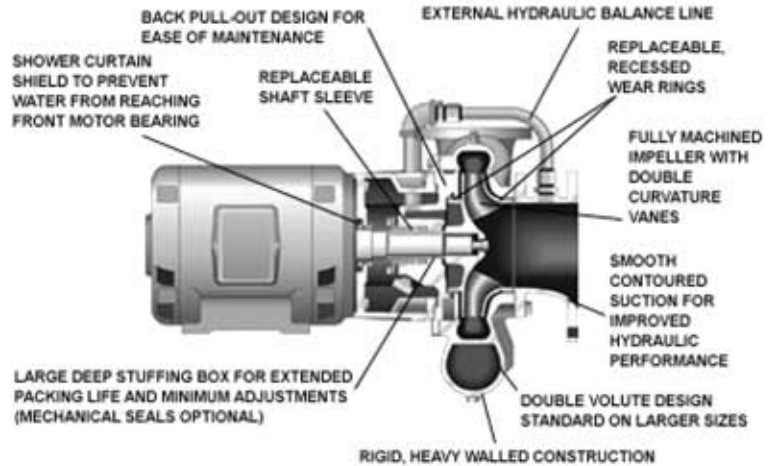

Engine Mount Pumps

- Direct SAE coupled
- Heavy duty stress proof shaft
- Generously sized bearing
- Available with SAE #1, 2, 3, or 4 bell housing adapter
- Available with SAE 8", 10", 11.5", or 14" rubber disc drive

